



# Tarron MS Airport

Snowplow



The MS snow ploughs are multi-blade special snow ploughs with optional high or low blade heights and based on the successful Tarron series. The MS series is specially designed for fast and highly efficient snow clearance on airport runways, taxiways and aprons. With their innovative override system, they easily avoid ground obstacles such as concrete elevations or ground lamps during operation.

## Highlights

- Aggressive 45° snow plough for high clearing quality
- Optimum snow removal even with large amounts of snow
- Suitable for all types of snow
- Customizable depending on application area (K- foldable external segments, A- ejection barriers or W- quick release version)

## Your benefits

- Safe driving over obstacles without damaging the snow plough thanks to the automatic override system.
- Prevention of unwanted snow deposits on sensitive areas such as aprons thanks to the ejection barrier (A-version ).
- Efficient and reliable removal of residual snow with the hydraulic fine-clearing bar.

## Performance features

### Plow blade

Its multi-blade system makes the Tarron MS snow plough highly adaptable to the traffic area to be cleared. Depending on the length of the cutting edge - which ranges from 189 to 315 in - the MS ploughs consist of five to eight ploughshares, each equipped with a special Vulkollan clearing rail. Pre-tensioned blade segments allow aggressive use.

In the option with reduced blade height, each MS series snow plough is 8.7 in lower on the left, centre and right. The shape of the clearing blade is designed for wide ejection rates even at low feed rates, with a 45° angle of attack. This makes the MS suitable for clearing in formation. An optional fine finish blade removes any remaining snow and thus reduces the use of de-icing agents.

Each blade is held in position by two reinforced springs, while the outer blade segments have three springs, it provides better stability when overriding the obstacles.



### Override security system

The automatic and maintenance-free override security system allows safe and smooth driving over obstacles without damaging the snow plough. Over-riding ground obstacles, such as concrete elevations or floor lamps, is therefore no problem. Shock absorber strips absorb the starting impact and reduce noise emission.

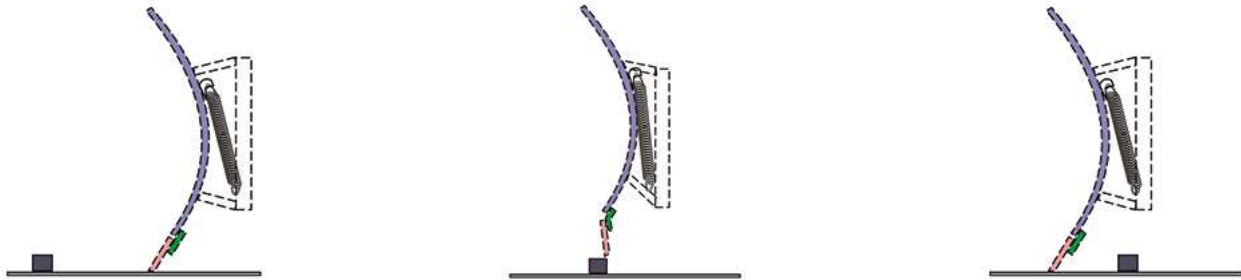

### Cutting edges

#### Slush cutting edge PUR

PUR cutting edges are often used for the airport areas. These cutting edges allow for more efficient snow clearance without causing any damage to either the surfaces or to the floor lamps. The PUR cutting edges represent a very high slide resistance and low noise level.

#### Rubber cutting edge (only for MS48.2) (R)

Due to the flexible and elastic characteristics of rubber, it glides smoothly over the surface. A rubber cutting edge is especially efficient when clearing snow slush.

#### GuKo cutting edge (only for MS48.2) (GK 5)

A GK cutting edge allows for more efficient snow slush clearing with longer service life and less friction. This cutting edge is made of steel, rubber and corundum and is therefore more aggressive than a rubber cutting edge.

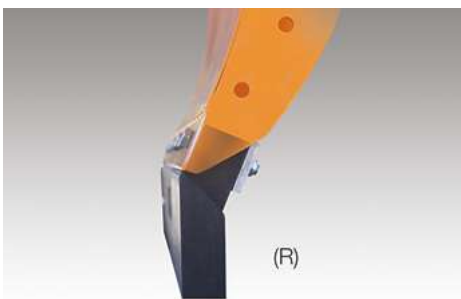

## Lifting device and angling system

A precise, parallel lifting device for lifting, lowering and swivelling the plough not only creates a large ground clearance during transport, but also allows for tension-free swivelling. A special design minimizes the distance of the gravity point to the front axle providing a better weight distribution. Two hydraulic cylinders capable of sustaining high actuating forces are used for the side changeover.

## Working support devices

### Castor wheels

The infinitely height-adjustable castor wheels with optional splash guards ensure precise adjustment of the snow plough and provide appropriate aggressiveness during snow clearing. They support the frame when driving over obstacles and extend the service life of the cutting edge.

### Snow deflector

A snow deflector prevents poor visibility due to snow swirling up to the windscreen of the vehicle. There are two variants to choose from.

1. an elastic snow deflector made of polyurethane, suitable for all kind of snow. Due to its special joint covers, it prevents slush from getting between the blades.

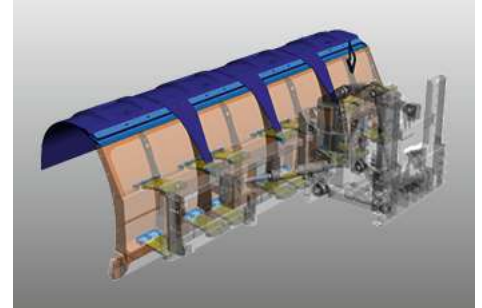

2. an adjustable snow deflector made of cloth. This version is particularly suitable for powder snow and high speeds. A combination with the polyurethane or rubber snow deflector is possible.



### Fine finish blade

The snow ploughs can be equipped with a very efficient fine finish blade. With its help, the remaining snow is thoroughly removed, increasing safety and reducing the use of de-icing agents.



## Options

### A-version - snow ejection barrier

The A-version transforms a standard snow plough on demand in to a U-shaped snow plough which allows collecting snow. The ejection barrier, left and right, can be operated while driving what makes the plough a flexible tool while clearing snow.

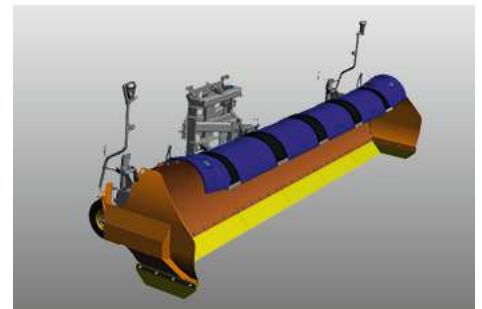

### K-version - foldable outer segments

The K-version allows to reduce the passing width of the plough in order to save a parking space.

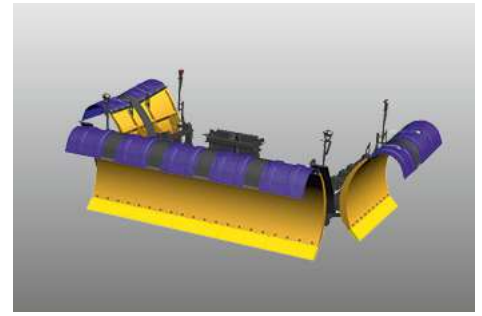

### W-version - quick release system

The W-version, containing an additional quick release system, saves time when attaching the snow plough to a truck.

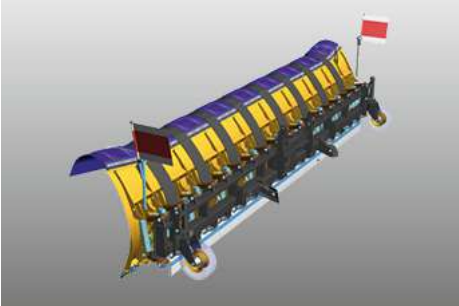

## Gallery



## Related products

### TJS / TJS-C

Runway clearing



### CJS

Runway clearing



### CJS-DI

Runway clearing





Trust in our many years of uniquely diverse experience. **Get in touch with us.** We'll find the right solution for your specific challenge.

## Technical data

	MS 48.2	MS 48.2N	MS 48.2N-A
<b>Construction</b>			
Number of blades	5	5	5
<b>Dimensions</b>			
Plow height centre, with elastomer	57.2"	46"	46"
Plow height right and left, with elastomer	60.9"	50.9"	49 1/2"
Length at cutting edge	15' 9"	15' 9"	15' 9"
Moldboard length	15' 9"	15' 9"	-
<b>Operational Dimensions</b>			
Clearing width	13' 6" at 32°	13' 6" at 32°	13' 6" at 32° 16' U-shaped
<b>Weights</b>			
Approx. weight with PUR cutting edges, wheels	2,899 lbs	-	3,148 lbs
Approx. weight with PUR cover, cutting edges, wheels	3,384 lbs	3,208 lbs	-
	MS 56.2	MS 56.2N	MS 56.2N-A
<b>Construction</b>			
Number of blades	6	6	6
<b>Dimensions</b>			
Plow height centre, with elastomer	57.2"	46"	46"
Plow height right and left, with elastomer	60.9"	50.9"	49 1/2"
Length at cutting edge	15' 1"	18' 5"	18' 5"
Moldboard length	18' 5"	18' 5"	-
<b>Operational Dimensions</b>			
Clearing width	15' 7" at 32°	15' 7" at 32°	15' 9" at 32° 18' 7" U-shaped
<b>Weights</b>			
Approx. weight with PUR cutting edges, wheels	3,219 lbs	3,020 lbs	3,565 lbs
Approx. weight with PUR cover, cutting edges, wheels	3,792 lbs	3,594 lbs	-
	MS 64.2	MS 64.2N	MS 64.2N-A
<b>Construction</b>			
Number of blades	7	7	7
<b>Dimensions</b>			
Plow height centre, with elastomer	57.2"	46"	46"
Plow height right and left, with elastomer	60.9"	50.9"	49 1/2"
Length at cutting edge	21'	21'	21'
Moldboard length	21'	21'	-
<b>Operational Dimensions</b>			
Clearing width	17' 10" at 32°	17' 10" at 32°	17' 10" at 32° 21' 3" U-shaped
<b>Weights</b>			
Approx. weight with PUR cutting edges, wheels	3,505 lbs	3,340 lbs	3,717 lbs
Approx. weight with PUR cover, cutting edges, wheels	4,178 lbs	4,001 lbs	-
	MS 72.2	MS 72.2K	MS 72.2N
<b>Construction</b>			
Number of blades	8	8	8

	MS 72.2	MS 72.2K	MS 72.2N
<b>Dimensions</b>			
Plow height centre, with elastomer	57.2"	56 1/2"	46"
Plow height right and left, with elastomer	60.9"	60.9"	50.9"
Length at cutting edge	23' 8"	23' 8"	23' 8"
Moldboard length	23' 8"	23' 8"	23' 8"

<b>Operational Dimensions</b>			
Clearing width	20' 1" at 32°	20' 1" at 32°	20' 1" at 32°

<b>Weights</b>			
Approx. weight with PUR cutting edges, wheels	3,825 lbs	4,079 lbs	3,571 lbs
Approx. weight with PUR cover, cutting edges, wheels	4,586 lbs	4,861 lbs	4,321 lbs

	MS 72.2N-K	MS 72.2N-W	MS 72.2W
<b>Construction</b>			
Number of blades	8	8	8

<b>Dimensions</b>			
Plow height centre, with elastomer	46"	45.7"	56 1/2"
Plow height right and left, with elastomer	50.9"	50.9"	60.9"
Length at cutting edge	23' 8"	-	23' 8"
Moldboard length	23' 8"	23' 8"	23' 8"

<b>Operational Dimensions</b>			
Clearing width	20' 1" at 32°	20' 1" at 32°	20' 1" at 32°

<b>Weights</b>			
Approx. weight with PUR cutting edges, wheels	3,880 lbs	4,557 lbs	4,791 lbs
Approx. weight with PUR cover, cutting edges, wheels	4,663 lbs	-	-

	MS 80.2K	MS 80.2N-K	MS 80.2N-W
<b>Construction</b>			
Number of blades	8	8	8

<b>Dimensions</b>			
Plow height centre, with elastomer	56 1/2"	46"	45.7"
Plow height right and left, with elastomer	60.9"	50.9"	50.9"
Length at cutting edge	26' 3"	26' 3"	26' 3"
Moldboard length	26' 3"	26' 3"	26' 3"

<b>Operational Dimensions</b>			
Clearing width	22' 3" at 32°	22' 3" at 32°	22' 3" at 32°

<b>Weights</b>			
Approx. weight with PUR cutting edges, wheels	4,244 lbs	3,979 lbs	4,735.5 lbs
Approx. weight with PUR cover, cutting edges, wheels	5,082 lbs	4,817 lbs	-

	MS 80.2W
<b>Construction</b>	
Number of blades	8
<b>Dimensions</b>	
Plow height centre, with elastomer	56 1/2"
Plow height right and left, with elastomer	60.9"
Length at cutting edge	26' 3"
Moldboard length	26' 3"
<b>Operational Dimensions</b>	

	<b>MS 80.2W</b>
Clearing width	22' 4" at 32°
<b>Weights</b>	
Approx. weight with PUR cutting edges, wheels	5,115 lbs



Aebi Schmidt North America Inc.  
201 MB Lane  
Chilton, WI 53014, USA  
Phone: +1 800 558 5800  
[www.aebi-schmidt.com](http://www.aebi-schmidt.com)

© Aebi Schmidt Group  
All rights reserved.  
Technical data is subject to change.  
Illustrations are not binding.  
Errors and amendments excepted.

Document created on 27 FEB 2026

